

SECRETARIA DE SEGURIDAD Y PROTECCION CIUDADANA

FORMATO GENERAL

SISTEMA NACIONAL DE SEGURIDAD PUBLICA

AVANCE EN LA APLICACION DE LOS RECURSOS ASIGNADOS A LOS PROGRAMAS DE SEGURIDAD PUBLICA 2015

(cifras al 31 de Diciembre del 2015)

(PESOS)

ENTIDAD FEDERATIVA: CHIAPAS

GOBIERNO DEL
ESTADO DE CHIAPAS

TIPO DE MA CAPITULO	ANEXO TECNICO/PROGRAMA CON PRIORIDAD NACIONAL	FINANCIAMIENTO CONJUNTO														
		IMPORTE CONVENIDO			COMPROMETIDO			DEVENGADO			PAGADO			SALDO POR EJERCER		
		FEDERAL	ESTATAL	TOTAL	FEDERAL	ESTATAL	TOTAL	FEDERAL	ESTATAL	TOTAL	FEDERAL	ESTATAL	TOTAL	FEDERAL	ESTATAL	TOTAL
3	Profesionalización de las Instituciones de Seguridad Pública	6,750,000.00	0.00	6,750,000.00	6,200,000.00	0.00	6,200,000.00	6,200,000.00	0.00	6,200,000.00	6,200,000.00	0.00	6,200,000.00	550,000.00	0.00	550,000.00
3000	Servicios Generales	6,750,000.00	0.00	6,750,000.00	6,200,000.00	0.00	6,200,000.00	6,200,000.00	0.00	6,200,000.00	6,200,000.00	0.00	6,200,000.00	550,000.00	0.00	550,000.00
8	Nuevo Sistema de Justicia Penal	11,900,000.00	0.00	11,900,000.00	11,900,000.00	0.00	11,900,000.00	11,900,000.00	0.00	11,900,000.00	11,900,000.00	0.00	11,900,000.00	0.00	0.00	0.00
3000	Servicios Generales	11,900,000.00	0.00	11,900,000.00	11,900,000.00	0.00	11,900,000.00	11,900,000.00	0.00	11,900,000.00	11,900,000.00	0.00	11,900,000.00	0.00	0.00	0.00
9	Fortalecimiento de las Capacidades Humanas y Tecnológicas del Sistema Penitenciario Nacional	39,934,456.00	0.00	39,934,456.00	19,142,681.08	0.00	19,142,681.08	19,142,681.08	0.00	19,142,681.08	19,064,619.74	0.00	19,064,619.74	20,887,925.17	0.00	20,887,925.17
2000	Materiales y Suministros	3,593,500.00	0.00	3,593,500.00	3,584,492.22	0.00	3,584,492.22	3,584,492.22	0.00	3,584,492.22	3,584,492.22	0.00	3,584,492.22	9,007.78	0.00	9,007.78
5000	Bienes Muebles, Inmuebles e Intangibles	19,593,550.00	0.00	19,593,550.00	9,668,537.29	0.00	9,668,537.29	9,668,537.29	0.00	9,668,537.29	9,668,537.29	0.00	9,668,537.29	9,925,012.71	0.00	9,925,012.71
6000	Inversión Pública	16,747,406.00	0.00	16,747,406.00	5,889,651.57	0.00	5,889,651.57	5,889,651.57	0.00	5,811,590.23	5,811,590.23	0.00	5,811,590.23	10,953,904.68	0.00	10,953,904.68
11	Sistema Nacional de Información (Base de datos)	0.00	4,888,985.48	4,888,985.48	0.00	4,252,963.11	4,252,963.11	0.00	4,252,963.11	4,252,963.11	0.00	4,252,963.11	0.00	636,022.37	636,022.37	
1000	Servicios Personales	0.00	4,472,393.35	4,472,393.35	0.00	4,063,061.96	4,063,061.96	0.00	4,063,061.96	4,063,061.96	0.00	4,063,061.96	0.00	409,331.39	409,331.39	
3000	Servicios Generales	0.00	85,831.16	85,831.16	0.00	78,669.91	78,669.91	0.00	78,669.91	78,669.91	0.00	78,669.91	0.00	7,161.27	7,161.27	
4000	Transferencias, Asignaciones, Subsidios y Otras Ayudas	0.00	330,760.95	330,760.95	0.00	111,231.24	111,231.24	0.00	111,231.24	111,231.24	0.00	111,231.24	0.00	219,529.71	219,529.71	
17	Fortalecimiento de Programas Prioritarios de las Instituciones Estatales de Seguridad Pública e Impartición de Justicia	66,550,830.79	0.00	66,550,830.79	54,944,649.22	0.00	54,944,649.22	46,714,044.50	0.00	46,714,044.50	46,425,970.02	0.00	46,425,970.02	20,124,860.77	0.00	20,124,860.77
2000	Materiales y Suministros	8,587,949.00	0.00	8,587,949.00	8,546,063.38	0.00	8,546,063.38	8,546,063.38	0.00	8,546,063.38	8,546,063.38	0.00	8,546,063.38	1,885.62	0.00	41,885.62
3000	Servicios Generales	2,758,200.00	0.00	2,758,200.00	2,754,400.00	0.00	2,754,400.00	2,754,400.00	0.00	2,754,400.00	2,754,400.00	0.00	2,754,400.00	3,800.00	0.00	3,800.00
5000	Bienes Muebles, Inmuebles e Intangibles	27,764,224.00	0.00	27,764,224.00	18,276,760.08	0.00	18,276,760.08	18,276,760.08	0.00	18,276,760.08	18,276,760.08	0.00	18,276,760.08	9,487,463.92	0.00	9,487,463.92
6000	Inversión Pública	27,440,457.79	0.00	27,440,457.79	25,367,425.76	0.00	25,367,425.76	17,136,821.04	0.00	17,136,821.04	16,848,746.56	0.00	16,848,746.56	10,591,711.23	0.00	10,591,711.23
3	Profesionalización de las Instituciones de Seguridad Pública SSyPC (Referendo FASP 2014)	937,500.00	0.00	937,500.00	937,500.00	0.00	937,500.00	937,500.00	0.00	937,500.00	937,500.00	0.00	937,500.00	0.00	0.00	0.00
3000	Servicios Generales	937,500.00	0.00	937,500.00	937,500.00	0.00	937,500.00	937,500.00	0.00	937,500.00	937,500.00	0.00	937,500.00	0.00	0.00	0.00
8	Nuevo Sistema de Justicia Penal SSyPC (Referendo FASP 2014)	5,937,500.00	0.00	5,937,500.00	5,937,500.00	0.00	5,937,500.00	5,937,500.00	0.00	5,937,500.00	5,937,500.00	0.00	5,937,500.00	0.00	0.00	0.00
3000	Servicios Generales	5,937,500.00	0.00	5,937,500.00	5,937,500.00	0.00	5,937,500.00	5,937,500.00	0.00	5,937,500.00	5,937,500.00	0.00	5,937,500.00	0.00	0.00	0.00
9	Fortalecimiento de las Capacidades Humanas y Tecnológicas del Sistema Penitenciario Nacional (Referendo FASP 2014)	19,679,685.68	0.00	19,679,685.68	19,190,009.82	0.00	19,190,009.82	19,190,009.82	0.00	19,190,009.82	16,190,009.82	0.00	16,190,009.82	489,575.86	0.00	489,575.86

SECRETARIA DE SEGURIDAD Y PROTECCION CIUDADANA

FORMATO GENERAL

SISTEMA NACIONAL DE SEGURIDAD PUBLICA

AVANCE EN LA APLICACION DE LOS RECURSOS ASIGNADOS A LOS PROGRAMAS DE SEGURIDAD PUBLICA 2015

(cifras al 31 de Diciembre del 2015)

(PESOS)

ENTIDAD FEDERATIVA: CHIAPAS

GOBIERNO DEL
ESTADO DE CHIAPAS

PROGRAMA	CAPITULO	ANEXO TECNICO/PROGRAMA CON PRIORIDAD NACIONAL	FINANCIAMIENTO CONJUNTO																
			IMPORTE CONVENIDO			COMPROMETIDO			DEVENGADO			PAGADO			SALDO POR EJERCER				
			FEDERAL	ESTATAL	TOTAL	FEDERAL	ESTATAL	TOTAL	FEDERAL	ESTATAL	TOTAL	FEDERAL	ESTATAL	TOTAL	FEDERAL	ESTATAL	TOTAL		
	2000	Materiales y Suministros	88,275.00	0.00	88,275.00	0.00	0.00	0.00	0.00	0.00	0.00	0.00	0.00	0.00	0.00	0.00	88,275.00	0.00	88,275.00
	3000	Servicios Generales	2,743,500.00	0.00	2,743,500.00	2,741,958.20	0.00	2,741,958.20	2,741,958.20	0.00	2,741,958.20	2,741,958.20	0.00	2,741,958.20	1,541.80	0.00	1,541.80	0.00	1,541.80
	6000	Bienes Muebles, Inmuebles e Intangibles	6,166,107.00	0.00	6,166,107.00	5,767,245.00	0.00	5,767,245.00	5,767,245.00	0.00	5,767,245.00	2,767,245.00	0.00	2,767,245.00	398,862.00	0.00	398,862.00	0.00	398,862.00
	6000	Inversión Pública	10,681,703.68	0.00	10,681,703.68	10,680,806.62	0.00	10,680,806.62	10,680,806.62	0.00	10,680,806.62	10,680,806.62	0.00	10,680,806.62	897.06	0.00	897.06	0.00	897.06
3		Equipamiento de personal e instalaciones para centros de Readaptación Social (Economías 2009-2011)	2,843,240.21	417,171.67	3,260,411.88	2,820,680.93	412,779.64	3,233,360.57	2,820,680.93	412,779.64	3,233,360.57	2,820,680.93	412,779.64	3,233,360.57	2,659.28	4,392.03	27,051.31		
	2000	Materiales y Suministros	314,704.83	121,236.32	435,941.15	314,699.72	117,797.61	432,496.33	314,699.72	117,797.61	432,496.33	314,699.72	117,797.61	432,496.33	6.11	3,438.71	3,444.82		
	3000	Servicios Generales	2,084,548.52	262,039.36	2,346,587.88	2,061,906.71	261,086.04	2,322,992.76	2,061,906.71	261,086.04	2,322,992.76	2,061,906.71	261,086.04	2,322,992.76	2,641.81	953.32	23,585.13		
	6000	Bienes Muebles, Inmuebles e Intangibles	443,886.86	3,895.99	477,882.85	443,975.50	33,895.99	477,871.49	443,975.50	33,895.99	477,871.49	443,975.50	33,895.99	477,871.49	11.36	0.00	11.36		
3		Equipamiento de personal e instalaciones de Seguridad Pública (Economías FASP 2010)	689.92	658,889.82	659,579.74	0.00	658,889.82	658,889.82	0.00	658,889.82	658,889.82	0.00	658,889.82	658,889.82	689.92	0.00	689.92		
	6000	Bienes Muebles, Inmuebles e Intangibles	689.92	658,889.82	659,579.74	0.00	658,889.82	658,889.82	0.00	658,889.82	658,889.82	0.00	658,889.82	658,889.82	689.92	0.00	689.92		
9		Fortalecimiento de las Capacidades Humanas y Tecnológicas del Sistema Penitenciario Nacional (Economías FASP 2012)	48,535.56	0.00	48,535.56	48,140.00	0.00	48,140.00	48,140.00	0.00	48,140.00	48,140.00	0.00	48,140.00	395.56	0.00	395.56		
	6000	Bienes Muebles, Inmuebles e Intangibles	48,535.56	0.00	48,535.56	48,140.00	0.00	48,140.00	48,140.00	0.00	48,140.00	48,140.00	0.00	48,140.00	395.56	0.00	395.56		
17		Fortalecimiento a Instituciones de seguridad Pública y Procuración de Justicia (Economías FASP 2012)	2,807,865.45	1,579,740.38	4,387,605.83	2,805,762.97	1,577,242.34	4,383,005.31	2,805,762.97	1,577,242.34	4,383,005.31	2,805,762.97	1,577,242.34	4,383,005.31	2,102.48	2,498.04	4,600.52		
	2000	Materiales y Suministros	224,399.00	0.00	224,399.00	224,399.00	0.00	224,399.00	224,399.00	0.00	224,399.00	224,399.00	0.00	224,399.00	0.00	0.00	0.00		
	6000	Bienes Muebles, Inmuebles e Intangibles	2,583,466.45	1,579,740.38	4,163,206.83	2,581,363.97	1,577,242.34	4,158,606.31	2,581,363.97	1,577,242.34	4,158,606.31	2,581,363.97	1,577,242.34	4,158,606.31	2,102.48	2,498.04	4,600.52		
17		Fortalecimiento de Programas Prioritarios de las Instituciones Estatales de seguridad Pública (Economías FASP 2013)	2,820,261.51	611,725.67	3,451,987.08	2,816,992.44	628,056.57	3,445,049.01	2,816,992.44	628,056.57	3,445,049.01	2,816,992.44	628,056.57	3,445,049.01	3,269.07	3,669.00	6,938.07		
	2000	Materiales y Suministros	0.00	265,540.00	265,540.00	0.00	281,871.00	281,871.00	0.00	281,871.00	281,871.00	0.00	281,871.00	281,871.00	0.00	3,669.00	3,669.00		
	6000	Bienes Muebles, Inmuebles e Intangibles	2,820,261.51	346,185.57	3,166,447.08	2,816,992.44	346,185.57	3,163,178.01	2,816,992.44	346,185.57	3,163,178.01	2,816,992.44	346,185.57	3,163,178.01	3,269.07	0.00	3,269.07		

C.P. ROBERTO LOPEZ MONZON

JEFE DEL AREA DE RECURSOS FINANCIEROS Y CONTABILIDAD



Main data table with columns for year, month, program, activity, budget, and execution status. Includes sub-headers for 'RECURSOS ORDINARIOS' and 'RECURSOS EXTRAORDINARIOS'.

Summary table with columns: META CONVIERTE Y MODIFICA, META ALCANZADA, META POR ALCANZAR. Includes sub-headers for 'UNIDAD DE MEDIDA', 'CANTIDAD', 'PERSONA', 'CANTIDAD', 'PERSONA'.



Main data table with columns for AÑO, MES, CODIGO, CUENTA, SUB CUENTA, PROGRAMA, PROYECTO, ACTIVIDAD, FONTEO, and various financial columns for federal and state resources, including sub-totals and commitments.

PROGRAMA	CAPITULO	ANEXO TECNICO/PROGRAMA CON PRIORIDAD NACIONAL	FINANCIAMIENTO CONJUNTO														
			IMPORTE CONVENIDO			COMPROMETIDO			DEVENGADO			PAGADO			SALDO POR EJERCER		
			FEDERAL	ESTATAL	TOTAL	FEDERAL	ESTATAL	TOTAL	FEDERAL	ESTATAL	TOTAL	FEDERAL	ESTATAL	TOTAL	FEDERAL	ESTATAL	TOTAL
		Profesionalización de las Instituciones de Seguridad Pública.	\$15,193,999.26	\$0.00	\$15,193,999.26	\$9,911,447.16	\$0.00	\$9,911,447.16	\$4,801,724.24	\$0.00	\$4,801,724.24	\$4,801,724.24	\$0.00	\$4,801,724.24	\$480,827.86	\$0.00	\$480,827.86
3	6000	Bienes Muebles, Inmuebles e Intangibles	\$9,293,999.26	\$0.00	\$9,293,999.26	\$7,553,319.00	\$0.00	\$7,553,319.00	\$1,264,532.00	\$0.00	\$1,264,532.00	\$1,264,532.00	\$0.00	\$1,264,532.00	\$476,148.26	\$0.00	\$476,148.26
	6000	Bienes Muebles, Inmuebles e Intangibles	\$5,900,000.00	\$0.00	\$5,900,000.00	\$2,358,128.16	\$0.00	\$2,358,128.16	\$3,537,192.24	\$0.00	\$3,537,192.24	\$3,537,192.24	\$0.00	\$3,537,192.24	\$4,679.60	\$0.00	\$4,679.60

Elaboró

Ing. José Alfredo Sánchez Aguilar
 Encargado de la Unidad de Planeación

Revisó

C.P. César Augusto Rojas Robles
 Encargado de la Unidad de Apoyo Admvo.

Vo.Bo.

Lic. Nicolás de Jesús Trinidad Náfate
 Director General

FORMATO GENERAL
SISTEMA NACIONAL DE SEGURIDAD PUBLICA
AVANCE EN LA APLICACIÓN DE LOS RECURSOS ASIGNADOS A LOS PROGRAMAS DE SEGURIDAD PÚBLICA 2015
(Cifras al 31 de Diciembre de 2015)
(PESOS)
ENTIDAD FEDERATIVA: CHIAPAS

Programa	Capítulo	Anexo Técnico/Programa con Prioridad Nacional	Financiamiento Conjunto														
			Importe Convenido			Comprometido			Devengado			Pagado			Saldo por Ejercer		
			Federal	Estatad	Total	Federal	Estatad	Total	Federal	Estatad	Total	Federal	Estatad	Total	Federal	Estatad	Total
8	6000	Nuevo Sistema de Justicia Penal (2015)	12,500,000.00	0.00	12,500,000.00	12,500,000.00	0.00	12,500,000.00	3,750,000.00	0.00	3,750,000.00	3,750,000.00	0.00	3,750,000.00	0.00	0.00	0.00
		Inversión Pública	12,500,000.00	0.00	12,500,000.00	12,500,000.00	0.00	12,500,000.00	3,750,000.00	0.00	3,750,000.00	3,750,000.00	0.00	3,750,000.00	0.00	0.00	0.00
8	6000	Nuevo Sistema de Justicia Penal (2014)	5,323,976.82	0.00	5,323,976.82	5,215,825.80	0.00	5,215,825.80	5,215,825.80	0.00	5,215,825.80	5,215,825.80	0.00	5,215,825.80	108,151.02	0.00	108,151.02
		Inversión Pública	5,323,976.82	0.00	5,323,976.82	5,215,825.80	0.00	5,215,825.80	5,215,825.80	0.00	5,215,825.80	5,215,825.80	0.00	5,215,825.80	108,151.02	0.00	108,151.02
8	6000	Nuevo Sistema de Justicia Penal (2013)	916,858.19	0.00	916,858.19	916,858.19	0.00	916,858.19	916,858.19	0.00	916,858.19	916,858.19	0.00	916,858.19	0.00	0.00	0.00
		Inversión Pública	916,858.19	0.00	916,858.19	916,858.19	0.00	916,858.19	916,858.19	0.00	916,858.19	916,858.19	0.00	916,858.19	0.00	0.00	0.00
8	6000	Nuevo Sistema de Justicia Penal (2012)	230,311.42	0.00	230,311.42	227,347.84	0.00	227,347.84	227,347.84	0.00	227,347.84	227,347.84	0.00	227,347.84	2,963.58	0.00	2,963.58
		Inversión Pública	230,311.42	0.00	230,311.42	227,347.84	0.00	227,347.84	227,347.84	0.00	227,347.84	227,347.84	0.00	227,347.84	2,963.58	0.00	2,963.58

Elaboró



C.P. Rubén Primitivo Orantes Trinidad
Jefe de Departamento

Visto Bueno



C.P. Julio César Vázquez Pérez
Director

FORMATO ESPECIFICO
FINANCIAMIENTO CONJUNTO PARA LA SEGURIDAD PUBLICA
ESTRUCTURA PROGRAMATICA PARA EL SEGUIMIENTO DE LOS RECURSOS 2015
ENTIDAD FEDERATIVA: CHIAPAS

Año	Entidad	Programa	Capítulo	Concepto	Partida Genérica	Partida Específica	Programas con Prioridad Nacional	Origen de los Recursos						Recursos Ejercidos						Recursos Devengados						Recursos Comprometidos						Recursos Disponibles						Meta Convenida y Modificada		Meta Alcanzada		Meta por Alcanzar				
								Aportaciones Federales (FASP)			Aportaciones Estatales			Financiamiento	Aportaciones Federales (FASP)			Aportaciones Estatales			Financiamiento	Aportaciones Federales (FASP)			Aportaciones Estatales			Financiamiento	Aportaciones Federales (FASP)			Aportaciones Estatales			Financiamiento	Aportaciones Federales (FASP)			Aportaciones Estatales			Financiamiento	Unidad de Medida	Cantidad Persona	Cantidad Persona	Cantidad Persona
								Federal	Municipal	Sub-Total	Estatal	Municipal	Sub-Total	Total	Federal	Municipal	Sub-Total	Estatal	Municipal	Sub-Total	Total	Federal	Municipal	Sub-Total	Estatal	Municipal	Sub-Total	Total	Federal	Municipal	Sub-Total	Estatal	Municipal	Sub-Total	Total	Federal	Municipal	Sub-Total	Estatal	Municipal	Sub-Total	Total				
							Total	18,971,146.43	0.00	18,971,146.43	0.00	0.00	0.00	18,971,146.43	10,110,091.83	0.00	10,110,091.83	0.00	0.00	0.00	10,110,091.83	10,110,091.83	0.00	0.00	0.00	0.00	0.00	10,110,091.83	18,860,091.83	0.00	18,860,091.83	0.00	0.00	0.00	18,860,091.83	111,114.00	0.00	111,114.00	0.00	0.00	0.00	111,114.00				
2015	8307	8	6000				Nuevo Sistema de Justicia Penal (2015)	12,500,000.00	0.00	12,500,000.00	0.00	0.00	0.00	12,500,000.00	3,750,000.00	0.00	3,750,000.00	0.00	0.00	0.00	3,750,000.00	3,750,000.00	0.00	0.00	0.00	0.00	3,750,000.00	12,500,000.00	0.00	12,500,000.00	0.00	0.00	0.00	12,500,000.00	0.00	0.00	0.00	0.00	0.00	0.00	0.00					
2015	8307	8	6000				Inversión Pública	12,500,000.00	0.00	12,500,000.00	0.00	0.00	0.00	12,500,000.00	3,750,000.00	0.00	3,750,000.00	0.00	0.00	0.00	3,750,000.00	3,750,000.00	0.00	0.00	0.00	0.00	0.00	3,750,000.00	12,500,000.00	0.00	12,500,000.00	0.00	0.00	0.00	12,500,000.00	0.00	0.00	0.00	0.00	0.00	0.00	0.00				
2015	8307	8	6000	6200			Obra pública en bienes propios	12,500,000.00	0.00	12,500,000.00	0.00	0.00	0.00	12,500,000.00	3,750,000.00	0.00	3,750,000.00	0.00	0.00	0.00	3,750,000.00	3,750,000.00	0.00	0.00	0.00	0.00	0.00	3,750,000.00	12,500,000.00	0.00	12,500,000.00	0.00	0.00	0.00	12,500,000.00	0.00	0.00	0.00	0.00	0.00	0.00	0.00				
2015	8307	8	6000	6200	622		Edificación no habitacional	12,500,000.00	0.00	12,500,000.00	0.00	0.00	0.00	12,500,000.00	3,750,000.00	0.00	3,750,000.00	0.00	0.00	0.00	3,750,000.00	3,750,000.00	0.00	0.00	0.00	0.00	0.00	3,750,000.00	12,500,000.00	0.00	12,500,000.00	0.00	0.00	0.00	12,500,000.00	0.00	0.00	0.00	0.00	0.00	0.00	0.00				
2015	8307	8	6000	6200	622	62201	Obras de construcción para edificios no habitacionales	12,500,000.00	0.00	12,500,000.00	0.00	0.00	0.00	12,500,000.00	3,750,000.00	0.00	3,750,000.00	0.00	0.00	0.00	3,750,000.00	3,750,000.00	0.00	0.00	0.00	0.00	0.00	3,750,000.00	12,500,000.00	0.00	12,500,000.00	0.00	0.00	0.00	12,500,000.00	0.00	0.00	0.00	0.00	0.00	0.00	0.00	Obra	1	0.01	0.99
2014	8307	8	6000				Nuevo Sistema de Justicia Penal (2014)	5,323,976.82	0.00	5,323,976.82	0.00	0.00	0.00	5,323,976.82	5,215,825.80	0.00	5,215,825.80	0.00	0.00	0.00	5,215,825.80	5,215,825.80	0.00	0.00	0.00	0.00	0.00	5,215,825.80	5,215,825.80	0.00	5,215,825.80	0.00	0.00	0.00	5,215,825.80	108,151.02	0.00	108,151.02	0.00	0.00	0.00	108,151.02				
2014	8307	8	6000				Inversión Pública	5,323,976.82	0.00	5,323,976.82	0.00	0.00	0.00	5,323,976.82	5,215,825.80	0.00	5,215,825.80	0.00	0.00	0.00	5,215,825.80	5,215,825.80	0.00	0.00	0.00	0.00	0.00	5,215,825.80	5,215,825.80	0.00	5,215,825.80	0.00	0.00	0.00	5,215,825.80	108,151.02	0.00	108,151.02	0.00	0.00	0.00	108,151.02				
2014	8307	8	6000	6200			Obra pública en bienes propios	5,323,976.82	0.00	5,323,976.82	0.00	0.00	0.00	5,323,976.82	5,215,825.80	0.00	5,215,825.80	0.00	0.00	0.00	5,215,825.80	5,215,825.80	0.00	0.00	0.00	0.00	0.00	5,215,825.80	5,215,825.80	0.00	5,215,825.80	0.00	0.00	0.00	5,215,825.80	108,151.02	0.00	108,151.02	0.00	0.00	0.00	108,151.02				
2014	8307	8	6000	6200	622		Edificación no habitacional	5,323,976.82	0.00	5,323,976.82	0.00	0.00	0.00	5,323,976.82	5,215,825.80	0.00	5,215,825.80	0.00	0.00	0.00	5,215,825.80	5,215,825.80	0.00	0.00	0.00	0.00	0.00	5,215,825.80	5,215,825.80	0.00	5,215,825.80	0.00	0.00	0.00	5,215,825.80	108,151.02	0.00	108,151.02	0.00	0.00	0.00	108,151.02				
2014	8307	8	6000	6200	622	62201	Obras de construcción para edificios no habitacionales	5,323,976.82	0.00	5,323,976.82	0.00	0.00	0.00	5,323,976.82	5,215,825.80	0.00	5,215,825.80	0.00	0.00	0.00	5,215,825.80	5,215,825.80	0.00	0.00	0.00	0.00	0.00	5,215,825.80	5,215,825.80	0.00	5,215,825.80	0.00	0.00	0.00	5,215,825.80	108,151.02	0.00	108,151.02	0.00	0.00	0.00	108,151.02	Obra	1	1	0
2013	8307	8	6000				Nuevo Sistema de Justicia Penal (2013)	916,858.19	0.00	916,858.19	0.00	0.00	0.00	916,858.19	916,858.19	0.00	916,858.19	0.00	0.00	0.00	916,858.19	916,858.19	0.00	0.00	0.00	0.00	0.00	916,858.19	916,858.19	0.00	916,858.19	0.00	0.00	0.00	916,858.19	0.00	0.00	0.00	0.00	0.00	0.00	0.00				
2013	8307	8	6000				Inversión Pública	916,858.19	0.00	916,858.19	0.00	0.00	0.00	916,858.19	916,858.19	0.00	916,858.19	0.00	0.00	0.00	916,858.19	916,858.19	0.00	0.00	0.00	0.00	0.00	916,858.19	916,858.19	0.00	916,858.19	0.00	0.00	0.00	916,858.19	0.00	0.00	0.00	0.00	0.00	0.00	0.00				
2013	8307	8	6000	6200			Obra pública en bienes propios	916,858.19	0.00	916,858.19	0.00	0.00	0.00	916,858.19	916,858.19	0.00	916,858.19	0.00	0.00	0.00	916,858.19	916,858.19	0.00	0.00	0.00	0.00	0.00	916,858.19	916,858.19	0.00	916,858.19	0.00	0.00	0.00	916,858.19	0.00	0.00	0.00	0.00	0.00	0.00	0.00				
2013	8307	8	6000	6200	622		Edificación no habitacional	916,858.19	0.00	916,858.19	0.00	0.00	0.00	916,858.19	916,858.19	0.00	916,858.19	0.00	0.00	0.00	916,858.19	916,858.19	0.00	0.00	0.00	0.00	0.00	916,858.19	916,858.19	0.00	916,858.19	0.00	0.00	0.00	916,858.19	0.00	0.00	0.00	0.00	0.00	0.00	0.00				
2013	8307	8	6000	6200	622	62202	Mantenimiento y rehabilitación para edificios no habitacionales	916,858.19	0.00	916,858.19	0.00	0.00	0.00	916,858.19	916,858.19	0.00	916,858.19	0.00	0.00	0.00	916,858.19	916,858.19	0.00	0.00	0.00	0.00	0.00	916,858.19	916,858.19	0.00	916,858.19	0.00	0.00	0.00	916,858.19	0.00	0.00	0.00	0.00	0.00	0.00	0.00	Obra	4	4	0
2012	8307	8	6000				Nuevo Sistema de Justicia Penal (2012)	230,311.42	0.00	230,311.42	0.00	0.00	0.00	230,311.42	227,347.84	0.00	227,347.84	0.00	0.00	0.00	227,347.84	227,347.84	0.00	0.00	0.00	0.00	0.00	227,347.84	227,347.84	0.00	227,347.84	0.00	0.00	0.00	227,347.84	2,963.58	0.00	2,963.58	0.00	0.00	0.00	2,963.58				
2012	8307	8	6000				Inversión Pública	230,311.42	0.00	230,311.42	0.00	0.00	0.00	230,311.42	227,347.84	0.00	227,347.84	0.00	0.00	0.00	227,347.84	227,347.84	0.00	0.00	0.00	0.00	0.00	227,347.84	227,347.84	0.00	227,347.84	0.00	0.00	0.00	227,347.84	2,963.58	0.00	2,963.58	0.00	0.00	0.00	2,963.58				
2012	8307	8	6000	6200			Obra pública en bienes propios	230,311.42	0.00	230,311.42	0.00	0.00	0.00	230,311.42	227,347.84	0.00	227,347.84	0.00	0.00	0.00	227,347.84	227,347.84	0.00	0.00	0.00	0.00	0.00	227,347.84	227,347.84	0.00	227,347.84	0.00	0.00	0.00	227,347.84	2,963.58	0.00	2,963.58	0.00	0.00	0.00	2,963.58				
2012	8307	8	6000	6200	622		Edificación no habitacional	230,311.42	0.00	230,311.42	0.00	0.00	0.00	230,311.42	227,347.84	0.00	227,347.84	0.00	0.00	0.00	227,347.84	227,347.84	0.00	0.00	0.00	0.00	0.00	227,347.84	227,347.84	0.00	227,347.84	0.00	0.00	0.00	227,347.84	2,963.58	0.00	2,963.58	0.00	0.00	0.00	2,963.58				
2012	8307	8	6000	6200	622	62201	Obras de construcción para edificios no habitacionales	209,413.43	0.00	209,413.43	0.00	0.00	0.00	209,413.43	206,449.85	0.00	206,449.85	0.00	0.00	0.00	206,449.85	206,449.85	0.00	0.00	0.00	0.00	0.00	206,449.85	206,449.85	0.00	206,449.85	0.00	0.00	0												

FORMATO GENERAL
SISTEMA NACIONAL DE SEGURIDAD PÚBLICA
AVANCE EN LA APLICACIÓN DE LOS RECURSOS ASIGNADOS A LOS PROGRAMAS DE SEGURIDAD PÚBLICA 2015
Cifras al 31 de diciembre del 2015
(PESOS)

ENTIDAD FEDERATIVA: CHIAPAS
Procuraduría General de Justicia del Estado

PROGRAMA	CAPÍTULO	ANEXO TECNICO/PROGRAMA CON PRIORIDAD NACIONAL	FINANCIAMIENTO CONJUNTO														
			IMPORTE CONVENIDO			COMPROMETIDO			DEVENGADO			PAGADO			SALDO POR EJERCER		
			FEDERAL	ESTATAL	TOTAL	FEDERAL	ESTATAL	TOTAL	FEDERAL	ESTATAL	TOTAL	FEDERAL	ESTATAL	TOTAL	FEDERAL	ESTATAL	TOTAL
3		Profesionalización de las Instituciones de Seguridad Pública. (FASP-2015)	\$3,250,000.00	\$0.00	\$3,250,000.00	\$989,999.16	\$0.00	\$989,999.16	\$989,999.16	\$0.00	\$989,999.16	\$749,999.16	\$0.00	\$749,999.16	\$2,260,000.84	\$0.00	\$2,260,000.84
	3000	Servicios Generales	\$3,250,000.00	\$0.00	\$3,250,000.00	\$989,999.16	\$0.00	\$989,999.16	\$989,999.16	\$0.00	\$989,999.16	\$749,999.16	\$0.00	\$749,999.16	\$2,260,000.84	\$0.00	\$2,260,000.84
4		Instrumentación de la estrategia en el combate al secuestro (UECS). (FASP-2015)	\$35,200,000.00	\$0.00	\$35,200,000.00	\$25,143,580.00	\$0.00	\$25,143,580.00	\$25,143,580.00	\$0.00	\$25,143,580.00	\$25,143,580.00	\$0.00	\$25,143,580.00	\$10,056,420.00	\$0.00	\$10,056,420.00
	6000	Bienes Muebles, Inmuebles e Intangibles	\$25,200,000.00	\$0.00	\$25,200,000.00	\$25,143,580.00	\$0.00	\$25,143,580.00	\$25,143,580.00	\$0.00	\$25,143,580.00	\$25,143,580.00	\$0.00	\$25,143,580.00	\$56,420.00	\$0.00	\$56,420.00
	6000	Inversión Pública	\$10,000,000.00	\$0.00	\$10,000,000.00	\$0.00	\$0.00	\$0.00	\$0.00	\$0.00	\$0.00	\$0.00	\$0.00	\$0.00	\$0.00	\$0.00	\$0.00
8		Nuevo Sistema de Justicia Penal.(FASP-2015)	\$18,000,000.00	\$0.00	\$18,000,000.00	\$9,043,892.90	\$0.00	\$9,043,892.90	\$9,043,892.90	\$0.00	\$9,043,892.90	\$8,793,893.18	\$0.00	\$8,793,893.18	\$9,956,107.10	\$0.00	\$9,956,107.10
	3000	Servicios Generales	\$18,000,000.00	\$0.00	\$18,000,000.00	\$9,043,892.90	\$0.00	\$9,043,892.90	\$9,043,892.90	\$0.00	\$9,043,892.90	\$8,793,893.18	\$0.00	\$8,793,893.18	\$9,956,107.10	\$0.00	\$9,956,107.10
3		Profesionalización de las Instituciones de Seguridad Pública. (FASP-Referendo 2014)	\$1,000,000.00	\$0.00	\$1,000,000.00	\$880,746.70	\$0.00	\$880,746.70	\$880,746.70	\$0.00	\$880,746.70	\$880,746.70	\$0.00	\$880,746.70	\$119,253.30	\$0.00	\$119,253.30
	3000	Servicios Generales	\$1,000,000.00	\$0.00	\$1,000,000.00	\$880,746.70	\$0.00	\$880,746.70	\$880,746.70	\$0.00	\$880,746.70	\$880,746.70	\$0.00	\$880,746.70	\$119,253.30	\$0.00	\$119,253.30
8		Nuevo Sistema de Justicia Penal. (FASP-Referendo 2014)	\$17,524,700.88	\$0.00	\$17,524,700.88	\$16,804,543.15	\$0.00	\$16,804,543.15	\$16,804,543.15	\$0.00	\$16,804,543.15	\$16,804,543.15	\$0.00	\$16,804,543.15	\$920,157.51	\$0.00	\$920,157.51
	3000	Servicios Generales	\$7,272,267.00	\$0.00	\$7,272,267.00	\$6,554,596.12	\$0.00	\$6,554,596.12	\$6,554,596.12	\$0.00	\$6,554,596.12	\$6,554,596.12	\$0.00	\$6,554,596.12	\$717,670.88	\$0.00	\$717,670.88
	6000	Inversión Pública	\$10,252,433.66	\$0.00	\$10,252,433.66	\$10,049,947.03	\$0.00	\$10,049,947.03	\$10,049,947.03	\$0.00	\$10,049,947.03	\$10,049,947.03	\$0.00	\$10,049,947.03	\$202,486.63	\$0.00	\$202,486.63
16		Genética forense. (FASP-Referendo 2014)	\$5,473,953.00	\$0.00	\$5,473,953.00	\$5,166,095.08	\$0.00	\$5,166,095.08	\$5,166,095.08	\$0.00	\$5,166,095.08	\$5,166,095.08	\$0.00	\$5,166,095.08	\$307,857.92	\$0.00	\$307,857.92
	2000	Materiales y Suministros	\$710,515.00	\$0.00	\$710,515.00	\$585,879.88	\$0.00	\$585,879.88	\$585,879.88	\$0.00	\$585,879.88	\$585,879.88	\$0.00	\$585,879.88	\$124,635.12	\$0.00	\$124,635.12
	6000	Bienes Muebles, Inmuebles e Intangibles	\$4,763,438.00	\$0.00	\$4,763,438.00	\$4,580,215.20	\$0.00	\$4,580,215.20	\$4,580,215.20	\$0.00	\$4,580,215.20	\$4,580,215.20	\$0.00	\$4,580,215.20	\$183,222.80	\$0.00	\$183,222.80
4		Instrumentación de la Estrategia en el Combate al Secuestro (UECS) FASP- Economías-2014	\$5,160,224.90	\$7,495,260.81	\$12,655,485.51	\$0.00	\$0.00	\$0.00	\$0.00	\$0.00	\$0.00	\$0.00	\$0.00	\$0.00	\$5,160,224.90	\$7,495,260.81	\$12,655,485.51
	6000	Inversión Pública	\$5,160,224.90	\$7,495,260.81	\$12,655,485.51	\$0.00	\$0.00	\$0.00	\$0.00	\$0.00	\$0.00	\$0.00	\$0.00	\$0.00	\$5,160,224.90	\$7,495,260.81	\$12,655,485.51
16		Genética forense. (FASP-Referendo 2013)	\$598,368.27	\$0.00	\$598,368.27	\$0.00	\$0.00	\$0.00	\$0.00	\$0.00	\$0.00	\$0.00	\$0.00	\$0.00	\$598,368.27	\$0.00	\$598,368.27
	2000	Materiales y Suministros	\$21,284.84	\$0.00	\$21,284.84	\$0.00	\$0.00	\$0.00	\$0.00	\$0.00	\$0.00	\$0.00	\$0.00	\$0.00	\$21,284.84	\$0.00	\$21,284.84
	6000	Bienes Muebles, Inmuebles e Intangibles	\$568,413.92	\$0.00	\$568,413.92	\$0.00	\$0.00	\$0.00	\$0.00	\$0.00	\$0.00	\$0.00	\$0.00	\$0.00	\$568,413.92	\$0.00	\$568,413.92
	6000	Inversión Pública	\$8,669.51	\$0.00	\$8,669.51	\$0.00	\$0.00	\$0.00	\$0.00	\$0.00	\$0.00	\$0.00	\$0.00	\$0.00	\$8,669.51	\$0.00	\$8,669.51
7		Acceso a la Justicia para las Mujeres.(FASP-Referendo 2013)	\$1,447,148.71	\$1,979,819.59	\$3,426,968.30	\$1,422,538.77	\$1,946,151.16	\$3,368,689.93	\$1,422,538.77	\$1,946,151.16	\$3,368,689.93	\$1,422,538.77	\$1,946,151.16	\$3,368,689.93	\$24,609.94	\$33,668.43	\$58,278.37
	6000	Inversión Pública	\$1,447,148.71	\$1,979,819.59	\$3,426,968.30	\$1,422,538.77	\$1,946,151.16	\$3,368,689.93	\$1,422,538.77	\$1,946,151.16	\$3,368,689.93	\$1,422,538.77	\$1,946,151.16	\$3,368,689.93	\$24,609.94	\$33,668.43	\$58,278.37

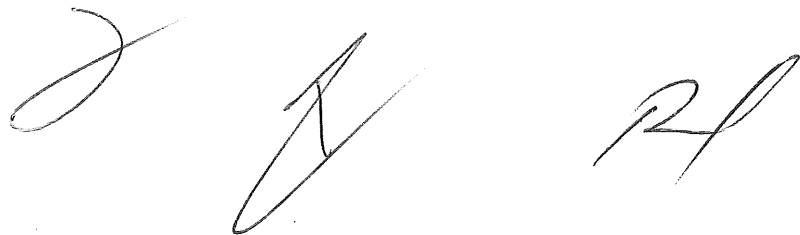

PROGRAMA	CAPITULO	ANEXO TECNICO/PROGRAMA CON PRIORIDAD NACIONAL	FINANCIAMIENTO CONJUNTO																
			IMPORTE CONVENIDO			COMPROMETIDO			DEVENGADO			PAGADO			SALDO POR EJERCER				
			FEDERAL	ESTATAL	TOTAL	FEDERAL	ESTATAL	TOTAL	FEDERAL	ESTATAL	TOTAL	FEDERAL	ESTATAL	TOTAL	FEDERAL	ESTATAL	TOTAL		
9		Infraestructura para la procuración de justicia. (FASP-Economías 2011 Y 2012)	\$259,019.00	\$0.00	\$259,019.00	\$0.00	\$0.00	\$0.00	\$0.00	\$0.00	\$0.00	\$0.00	\$0.00	\$0.00	\$0.00	\$0.00	\$259,019.00	\$0.00	\$259,019.00
	6000	Inversión Pública	\$259,019.00	\$0.00	\$259,019.00	\$0.00	\$0.00	\$0.00	\$0.00	\$0.00	\$0.00	\$0.00	\$0.00	\$0.00	\$0.00	\$0.00	\$259,019.00	\$0.00	\$259,019.00
14		Equipamiento de Personal e Instalaciones para la Procuración de Justicia (FASP-Economías 2009, 2010 Y 2011)	\$1,768,529.41	\$295,952.09	\$2,064,481.50	\$0.00	\$0.00	\$0.00	\$0.00	\$0.00	\$0.00	\$0.00	\$0.00	\$0.00	\$0.00	\$0.00	\$1,768,529.41	\$295,952.09	\$2,064,481.50
	5000	Bienes Muebles, Inmuebles e Intangibles	\$1,768,529.41	\$295,952.09	\$2,064,481.50	\$0.00	\$0.00	\$0.00	\$0.00	\$0.00	\$0.00	\$0.00	\$0.00	\$0.00	\$0.00	\$0.00	\$1,768,529.41	\$295,952.09	\$2,064,481.50

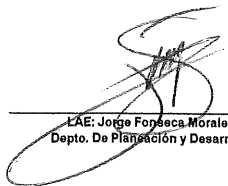
Realizó

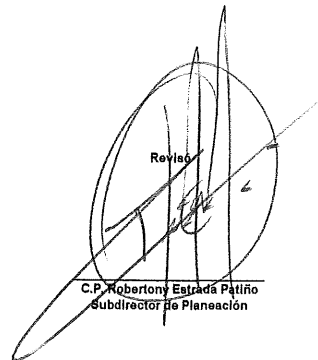
 LAE Jorge Fonseca Morales
 Depto. De Planeación y Desarrollo

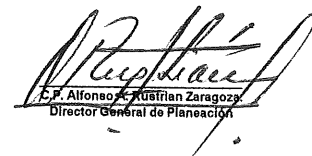
Revisó

 C.P. Robertony Estrada Patiño
 Subdirector de Planeación

Autorizó

 C.P. Alfonso A. Agustian Zaragoza
 Director General de Planeación

FORMATO GENERAL
SISTEMA NACIONAL DE SEGURIDAD PÚBLICA
AVANCE EN LA APLICACIÓN DE LOS RECURSOS ASIGNADOS A LOS PROGRAMAS DE SEGURIDAD PÚBLICA 2015
(Cifras al 31 de Diciembre del 2015)
(PESOS)

ENTIDAD FEDERATIVA: CHIAPAS

PROGRAMA	CAPÍTULO	ANEXO TECNICO/ PROGRAMA CON PRIORIDAD NACIONAL	FINANCIAMIENTO CONJUNTO														
			IMPORTE CONVENIDO			COMPROMETIDO			DEVENGADO			PAGADO			SALDO POR EJERCER		
			FEDERAL	ESTATAL	TOTAL	FEDERAL	ESTATAL	TOTAL	FEDERAL	ESTATAL	TOTAL	FEDERAL	ESTATAL	TOTAL	FEDERAL	ESTATAL	TOTAL
3		PROFESIONALIZACIÓN DE LAS INSTITUCIONES DE SEGURIDAD PÚBLICA	11,091,389.99	3,096,956.62	14,188,346.61	10,064,350.48	2,873,992.64	12,938,343.12	10,064,350.48	2,873,992.64	12,938,343.12	9,601,656.07	2,627,514.64	12,229,170.71	1,027,099.51	222,969.98	1,250,009.49
	3000	SERVICIOS GENERALES	11,091,389.99	3,096,956.62	14,188,346.61	10,064,350.48	2,873,992.64	12,938,343.12	10,064,350.48	2,873,992.64	12,938,343.12	9,601,656.07	2,627,514.64	12,229,170.71	1,027,099.51	222,969.98	1,250,009.49
		PROFESIONALIZACIÓN DE LAS INSTITUCIONES DE SEGURIDAD PÚBLICA (REFERENDO 2014)	4,000,000.00	0.00	4,000,000.00	4,000,000.00	0.00	4,000,000.00	4,000,000.00	0.00	4,000,000.00	4,000,000.00	0.00	4,000,000.00	0.00	0.00	0.00
	3000	SERVICIOS GENERALES	4,000,000.00	0.00	4,000,000.00	4,000,000.00	0.00	4,000,000.00	4,000,000.00	0.00	4,000,000.00	4,000,000.00	0.00	4,000,000.00	0.00	0.00	0.00
		RED NACIONAL DE TELECOMUNICACIONES	28,922,183.72	15,281,203.02	44,203,386.74	27,088,644.75	13,972,548.55	41,061,193.30	27,088,644.75	13,969,531.54	40,958,176.29	27,088,644.75	13,868,255.45	40,956,900.20	1,833,538.97	1,308,654.47	3,142,193.44
	1000	SERVICIOS PERSONALES	0.00	7,814,226.44	7,814,226.44	0.00	7,581,675.37	7,581,675.37	0.00	7,581,396.36	7,581,396.36	0.00	7,581,396.36	0.00	0.00	0.00	
	2000	MATERIALES Y SUMINISTROS	357,500.00	2,350,000.00	2,707,500.00	0.00	2,278,804.30	2,278,804.30	0.00	2,278,804.30	2,278,804.30	0.00	2,278,804.30	0.00	0.00	0.00	
	3000	SERVICIOS GENERALES	23,847,683.72	4,932,699.54	28,780,383.26	22,448,266.91	3,933,538.51	26,381,807.42	22,448,266.91	3,430,800.51	26,279,069.42	22,448,268.91	3,829,524.42	26,277,799.33	1,399,414.81	999,161.03	428,695.70
	4000	TRANSFERENCIAS, ASIGNACIONES, SUBSIDIOS Y OTRAS AYUDAS	0.00	184,277.04	184,277.04	0.00	178,530.37	178,530.37	0.00	178,530.37	178,530.37	0.00	178,530.37	0.00	0.00	0.00	
	5000	BIENES MUEBLES, INMUEBLES E INTANGIBLES	4,717,000.00	0.00	4,717,000.00	4,640,375.84	0.00	4,640,375.84	4,640,375.84	0.00	4,640,375.84	0.00	4,640,375.84	0.00	0.00	0.00	
		RED NACIONAL DE TELECOMUNICACIONES (REFERENDO 2014)	3,564,583.41	95,634.22	3,660,217.63	3,564,294.77	94,841.31	3,659,136.08	3,564,294.77	94,841.31	3,659,136.08	3,564,294.77	94,841.31	3,659,136.08	288.64	792.91	1,081.55
	2000	MATERIALES Y SUMINISTROS	0.00	31,434.22	31,434.22	0.00	31,434.10	31,434.10	0.00	31,434.10	31,434.10	0.00	31,434.10	0.00	0.12	0.12	
	3000	SERVICIOS GENERALES	3,061,000.00	64,200.00	3,125,200.00	3,060,711.36	63,407.21	3,124,118.57	3,060,711.36	63,407.21	3,124,118.57	3,060,711.36	63,407.21	3,124,118.57	288.64	792.79	1,081.43
	6000	INVERSION PUBLICA	503,583.41	0.00	503,583.41	503,583.41	0.00	503,583.41	503,583.41	0.00	503,583.41	0.00	503,583.41	0.00	0.00	0.00	
		RED NACIONAL DE TELECOMUNICACIONES (RENDIMIENTOS 2011, 2012 Y 2013)	3,586,309.61	1,316,946.17	4,903,255.78	2,954,632.31	1,308,852.89	4,263,485.20	2,954,632.31	1,308,852.89	4,263,485.20	2,936,908.27	1,300,668.14	4,237,576.41	631,577.30	8,093.28	639,770.58
	19	Comité de Domínguez	1,851,832.49	111,833.72	1,963,666.21	1,829,758.52	108,292.15	1,938,050.67	1,829,758.52	108,292.15	1,938,050.67	1,818,860.73	106,663.75	1,925,524.48	22,073.97	3,541.57	25,615.54
	2000	MATERIALES Y SUMINISTROS	47,076.86	3,541.57	50,618.43	41,760.00	0.00	41,760.00	41,760.00	0.00	41,760.00	41,760.00	0.00	41,760.00	0.00	0.00	0.00
	3000	SERVICIOS GENERALES	631,712.03	94,806.80	726,518.83	631,712.03	94,806.80	726,518.83	631,712.03	94,806.80	726,518.83	620,814.24	93,178.40	713,992.64	5,316.86	3,541.57	8,858.43
	5000	BIENES MUEBLES, INMUEBLES E INTANGIBLES	1,173,043.60	13,485.35	1,186,528.95	1,156,286.49	13,485.35	1,169,771.84	1,156,286.49	13,485.35	1,169,771.84	1,156,286.49	13,485.35	1,169,771.84	0.00	0.00	0.00
	65	Palenque	446,625.05	1,189,618.71	1,627,243.76	168,136.80	117,067.00	1,344,203.80	168,136.80	1,176,067.00	1,344,203.80	168,074.84	1,169,932.96	1,338,007.80	278,488.25	4,551.71	16,757.11
	2000	MATERIALES Y SUMINISTROS	81,862.62	42,018.82	123,881.44	81,862.62	41,941.86	123,804.48	81,862.62	41,941.86	123,804.48	81,862.62	41,941.86	123,804.48	0.00	0.00	0.00
	3000	SERVICIOS GENERALES	6,814.18	353,667.84	359,482.02	6,814.18	352,553.82	359,368.00	6,814.18	352,553.82	359,368.00	6,752.22	346,419.78	353,172.00	0.00	0.00	0.00
	5000	BIENES MUEBLES, INMUEBLES E INTANGIBLES	357,948.25	785,932.05	1,143,880.30	79,460.00	781,571.32	861,031.32	79,460.00	781,571.32	861,031.32	79,460.00	781,571.32	861,031.32	278,488.25	4,360.73	282,848.98
	101	Tuxtla Gutiérrez	1,287,852.07	24,493.74	1,312,345.81	956,736.99	24,493.74	981,230.73	956,736.99	24,493.74	981,230.73	949,972.70	24,071.43	974,044.13	331,115.08	0.00	331,115.08
	2000	MATERIALES Y SUMINISTROS	8,853.91	0.00	8,853.91	8,853.82	0.00	8,853.82	8,853.82	0.00	8,853.82	8,853.82	0.00	8,853.82	0.09	0.00	0.09
	3000	SERVICIOS GENERALES	556,758.96	24,493.74	581,252.70	556,758.94	24,493.74	581,252.68	556,758.94	24,493.74	581,252.68	549,994.65	24,071.43	574,066.08	0.02	0.00	0.02
	5000	BIENES MUEBLES, INMUEBLES E INTANGIBLES	722,239.20	0.00	722,239.20	391,124.23	0.00	391,124.23	391,124.23	0.00	391,124.23	391,124.23	0.00	391,124.23	0.00	0.00	0.00
		RED NACIONAL DE TELECOMUNICACIONES (RENDIMIENTOS 2013 Y 2014)	2,162,104.27	0.00	2,162,104.27	2,162,079.78	0.00	2,162,079.78	2,162,079.78	0.00	2,162,079.78	2,152,026.07	0.00	2,152,026.07	24.49	0.00	24.49
	78	San Cristóbal de las Casas	600,000.00	0.00	600,000.00	599,977.61	0.00	599,977.61	599,977.61	0.00	599,977.61	595,908.65	0.00	595,908.65	22.39	0.00	22.39
	2000	MATERIALES Y SUMINISTROS	82,739.18	0.00	82,739.18	82,716.79	0.00	82,716.79	82,716.79	0.00	82,716.79	82,716.79	0.00	82,716.79	22.39	0.00	22.39
	3000	SERVICIOS GENERALES	236,000.26	0.00	236,000.26	236,000.26	0.00	236,000.26	236,000.26	0.00	236,000.26	231,991.30	0.00	231,991.30	0.00	0.00	0.00
	5000	BIENES MUEBLES, INMUEBLES E INTANGIBLES	281,260.56	0.00	281,260.56	281,260.56	0.00	281,260.56	281,260.56	0.00	281,260.56	281,260.56	0.00	281,260.56	0.00	0.00	0.00
	78	Tapachula	1,562,104.27	0.00	1,562,104.27	1,562,102.17	0.00	1,562,102.17	1,562,102.17	0.00	1,562,102.17	1,556,117.42	0.00	1,556,117.42	2.10	0.00	2.10
	2000	MATERIALES Y SUMINISTROS	691,084.33	0.00	691,084.33	691,082.24	0.00	691,082.24	691,082.24	0.00	691,082.24	691,082.24	0.00	691,082.24	0.00	0.00	0.00
	3000	SERVICIOS GENERALES	347,115.69	0.00	347,115.69	347,115.68	0.00	347,115.68	347,115.68	0.00	347,115.68	341,130.93	0.00	341,130.93	0.01	0.00	0.01
	5000	BIENES MUEBLES, INMUEBLES E INTANGIBLES	523,904.25	0.00	523,904.25	523,904.25	0.00	523,904.25	523,904.25	0.00	523,904.25	523,904.25	0.00	523,904.25	0.00	0.00	0.00
		RED NACIONAL DE TELECOMUNICACIONES (ECONOMIAS 2009-2012)	3,755,386.64	3,868,022.11	7,623,408.75	3,755,352.46	3,836,848.74	7,592,201.20	3,755,352.46	3,836,848.74	7,592,201.20	3,745,906.67	3,828,693.04	7,574,599.71	34.18	31,173.37	31,207.55
	101	Reforma	1,671,261.49	2,754,585.22	4,425,846.71	1,671,256.41	2,723,417.61	4,394,674.02	1,671,256.41	2,723,417.61	4,394,674.02	1,663,721.24	2,719,017.04	4,382,738.28	5.08	31,167.61	31,172.69
	2000	MATERIALES Y SUMINISTROS	197,295.96	111,764.11	309,060.07	197,290.92	111,764.11	309,055.03	197,290.92	111,764.11	309,055.03	197,290.92	111,764.11	309,055.03	5.04	0.00	5.04

FORMATO GENERAL
SISTEMA NACIONAL DE SEGURIDAD PÚBLICA
AVANCE EN LA APLICACIÓN DE LOS RECURSOS ASIGNADOS A LOS PROGRAMAS DE SEGURIDAD PÚBLICA 2015
(Cifras al 31 de Diciembre del 2015)
(PESOS)

ENTIDAD FEDERATIVA: CHIAPAS

PROGRAMA	CAPÍTULO	ANEXO TECNICO/ PROGRAMA CON PRIORIDAD NACIONAL	IMPORTE CONVENIDO			COMPROMETIDO			DEVENGADO			PAGADO			SALDO POR EJERCER		
			FEDERAL	ESTATAL	TOTAL	FEDERAL	ESTATAL	TOTAL	FEDERAL	ESTATAL	TOTAL	FEDERAL	ESTATAL	TOTAL	FEDERAL	ESTATAL	TOTAL
	3000	SERVICIOS GENERALES	437,040.14	306,263.23	743,303.37	437,040.14	306,263.22	743,303.36	437,040.14	306,263.22	743,303.36	429,504.57	301,862.65	731,367.22	0.00	0.01	0.01
	5000	BIENES MUEBLES, INMUEBLES E INTANGIBLES	1,036,925.39	2,396,557.88	3,433,483.27	1,036,925.35	2,305,390.28	3,342,315.63	1,036,925.35	2,305,390.28	3,342,315.63	1,036,925.35	2,305,390.28	3,342,315.63	0.04	31,167.60	31,167.64
	101	San Cristóbal de las Casas	2,084,125.15	1,113,436.89	3,197,562.04	2,084,096.05	1,113,431.13	3,197,527.18	2,084,096.05	1,113,431.13	3,197,527.18	2,082,185.43	1,109,676.00	3,191,861.43	29.10	5.76	34.86
	2000	MATERIALES Y SUMINISTROS	79,181.12	83,264.00	162,445.12	79,181.04	83,263.91	162,444.95	79,181.04	83,263.91	162,444.95	79,181.04	83,263.91	162,444.95	0.08	0.09	0.17
	3000	SERVICIOS GENERALES	106,441.23	233,685.29	340,126.52	106,441.23	233,685.28	340,126.51	106,441.23	233,685.28	340,126.51	104,530.61	229,930.15	334,460.76	0.00	0.01	0.01
	5000	BIENES MUEBLES, INMUEBLES E INTANGIBLES	1,898,502.80	796,487.60	2,694,990.40	1,898,473.78	796,481.94	2,694,955.72	1,898,473.78	796,481.94	2,694,955.72	1,898,473.78	796,481.94	2,694,955.72	29.02	5.66	34.68
		RED NACIONAL DE TELECOMUNICACIONES (ECONOMIAS 2014)	400,000.00	0.00	400,000.00	399,999.70	0.00	399,999.70	399,999.70	0.00	399,999.70	399,999.70	0.00	399,999.70	0.30	0.00	0.30
	97	Tonalá	400,000.00	0.00	400,000.00	399,999.70	0.00	399,999.70	399,999.70	0.00	399,999.70	399,999.70	0.00	399,999.70	0.30	0.00	0.30
	5000	BIENES MUEBLES, INMUEBLES E INTANGIBLES	400,000.00	0.00	400,000.00	399,999.70	0.00	399,999.70	399,999.70	0.00	399,999.70	399,999.70	0.00	399,999.70	0.30	0.00	0.30
		SISTEMA NACIONAL DE INFORMACIÓN (BASE DE DATOS)	2,748,700.00	9,740,259.80	12,488,959.80	2,397,248.39	9,018,481.87	11,415,730.26	2,336,348.39	8,979,728.59	11,316,076.98	2,320,224.25	8,979,160.02	11,299,384.27	351,451.61	721,777.93	1,073,229.54
	1000	SERVICIOS PERSONALES	0.00	7,218,486.73	7,218,486.73	0.00	6,945,320.37	6,945,320.37	0.00	6,945,320.37	6,945,320.37	0.00	6,945,320.37	6,945,320.37	0.00	273,166.36	273,166.36
	2000	MATERIALES Y SUMINISTROS	0.00	1,645,000.00	1,645,000.00	0.00	1,345,589.73	1,345,589.73	0.00	1,345,589.73	1,345,589.73	0.00	1,345,589.73	1,345,589.73	0.00	299,410.27	299,410.27
	3000	SERVICIOS GENERALES	1,470,000.00	491,369.77	1,961,369.77	1,285,200.09	414,728.83	1,699,928.92	1,285,200.09	414,728.83	1,699,928.92	1,269,075.95	414,160.26	1,683,236.21	184,799.91	76,640.94	261,440.85
	4000	TRANSFERENCIAS, ASIGNACIONES, SUBSIDIOS Y OTRAS AYUDAS	0.00	205,903.30	205,903.30	0.00	196,583.10	196,583.10	0.00	196,583.10	196,583.10	0.00	196,583.10	196,583.10	0.00	9,320.20	9,320.20
	5000	BIENES MUEBLES, INMUEBLES E INTANGIBLES	1,278,700.00	179,500.00	1,458,200.00	1,112,048.30	116,259.84	1,228,308.14	1,051,148.30	77,506.56	1,128,654.86	1,051,148.30	77,506.56	1,128,654.86	166,651.70	63,240.16	229,891.86
		SISTEMA NACIONAL DE INFORMACIÓN (REFERENDO 2014)	647,980.48	67,337.60	715,318.08	647,980.48	40,188.96	688,169.44	647,980.48	40,188.96	688,169.44	647,980.48	40,188.96	688,169.44	0.00	27,148.64	27,148.64
	2000	MATERIALES Y SUMINISTROS	0.00	49,399.73	49,399.73	0.00	36,198.96	36,198.96	0.00	36,198.96	36,198.96	0.00	36,198.96	36,198.96	0.00	13,200.77	13,200.77
	3000	SERVICIOS GENERALES	258,833.32	17,937.87	276,771.19	258,833.32	3,990.00	262,823.32	258,833.32	3,990.00	262,823.32	258,833.32	3,990.00	262,823.32	0.00	13,947.87	13,947.87
	5000	BIENES MUEBLES, INMUEBLES E INTANGIBLES	389,147.16	0.00	389,147.16	389,147.16	0.00	389,147.16	389,147.16	0.00	389,147.16	389,147.16	0.00	389,147.16	0.00	0.00	0.00
		SISTEMA NACIONAL DE INFORMACIÓN (RENDIMIENTOS 2011 Y 2012)	514,000.00	0.00	514,000.00	511,119.20	0.00	511,119.20	511,119.20	0.00	511,119.20	511,119.20	0.00	511,119.20	2,880.80	0.00	2,880.80
	5000	BIENES MUEBLES, INMUEBLES E INTANGIBLES	514,000.00	0.00	514,000.00	511,119.20	0.00	511,119.20	511,119.20	0.00	511,119.20	511,119.20	0.00	511,119.20	2,880.80	0.00	2,880.80
		SISTEMA NACIONAL DE INFORMACIÓN (ECONOMIAS 2014)	64,000.00	0.00	64,000.00	63,996.61	0.00	63,996.61	63,996.61	0.00	63,996.61	63,996.61	0.00	63,996.61	3.39	0.00	3.39
	5000	BIENES MUEBLES, INMUEBLES E INTANGIBLES	64,000.00	0.00	64,000.00	63,996.61	0.00	63,996.61	63,996.61	0.00	63,996.61	63,996.61	0.00	63,996.61	3.39	0.00	3.39
		SERVICIOS DE LLAMADAS DE EMERGENCIA 066 Y DENUNCIA ANÓNIMA 089	34,350,319.33	14,442,447.34	48,792,766.67	25,990,286.40	13,779,134.06	39,769,420.46	25,990,286.40	13,779,134.06	39,769,420.46	25,858,886.40	13,779,134.06	39,638,020.46	8,360,032.99	663,313.28	9,023,346.21
	1000	SERVICIOS PERSONALES	0.00	13,256,704.91	13,256,704.91	0.00	12,684,377.54	12,684,377.54	0.00	12,684,377.54	12,684,377.54	0.00	12,684,377.54	12,684,377.54	0.00	572,327.37	572,327.37
	2000	MATERIALES Y SUMINISTROS	0.00	322,799.17	322,799.17	0.00	283,883.03	283,883.03	0.00	283,883.03	283,883.03	0.00	283,883.03	283,883.03	0.00	38,910.14	38,910.14
	3000	SERVICIOS GENERALES	18,217,968.31	605,133.88	18,823,102.19	11,056,115.95	579,654.50	11,635,770.45	11,056,115.95	579,654.50	11,635,770.45	10,924,715.55	579,654.50	11,504,370.45	7,161,852.36	25,479.38	7,187,331.74
	4000	TRANSFERENCIAS, ASIGNACIONES, SUBSIDIOS Y OTRAS AYUDAS	0.00	257,815.38	257,815.38	0.00	231,218.99	231,218.99	0.00	231,218.99	231,218.99	0.00	231,218.99	231,218.99	0.00	26,596.39	26,596.39
	5000	BIENES MUEBLES, INMUEBLES E INTANGIBLES	16,132,351.02	0.00	16,132,351.02	14,934,170.45	0.00	14,934,170.45	14,934,170.45	0.00	14,934,170.45	14,934,170.45	0.00	14,934,170.45	1,198,180.57	0.00	1,198,180.57
		SERVICIOS DE LLAMADAS DE EMERGENCIA 066 Y DENUNCIA ANÓNIMA 089 (RENDIMIENTOS 2013)	1,190,655.00	0.00	1,190,655.00	1,184,824.00	0.00	1,184,824.00	1,184,824.00	0.00	1,184,824.00	1,184,824.00	0.00	1,184,824.00	5,831.00	0.00	5,831.00
	3000	SERVICIOS GENERALES	1,190,655.00	0.00	1,190,655.00	1,184,824.00	0.00	1,184,824.00	1,184,824.00	0.00	1,184,824.00	1,184,824.00	0.00	1,184,824.00	5,831.00	0.00	5,831.00
		SERVICIOS DE LLAMADAS DE EMERGENCIA 066 Y DENUNCIA ANÓNIMA 089 (ECONOMIAS 2012)	299,716.02	17,768.00	317,484.02	299,715.77	17,768.00	317,483.77	299,715.77	17,768.00	317,483.77	299,715.77	17,768.00	317,483.77	0.25	0.00	0.25
	074	Reforma	76,540.02	17,768.00	94,308.02	76,540.02	17,768.00	94,308.02	76,540.02	17,768.00	94,308.02	76,540.02	17,768.00	94,308.02	0.00	0.00	0.00
	2000	MATERIALES Y SUMINISTROS	40,000.00	17,768.00	57,768.00	40,000.00	17,768.00	57,768.00	40,000.00	17,768.00	57,768.00	40,000.00	17,768.00	57,768.00	0.00	0.00	0.00

FORMATO GENERAL
SISTEMA NACIONAL DE SEGURIDAD PÚBLICA
AVANCE EN LA APLICACIÓN DE LOS RECURSOS ASIGNADOS A LOS PROGRAMAS DE SEGURIDAD PÚBLICA 2015
(Cifras al 31 de Diciembre del 2015)
(PESOS)

ENTIDAD FEDERATIVA: CHIAPAS

PROGRAMA	CAPÍTULO	ANEXO TECNICO/ PROGRAMA CON PRIORIDAD NACIONAL	FINANCIAMIENTO CONJUNTO														
			IMPORTE CONVENIDO			COMPROMETIDO			DEVENGADO			PAGADO			SALDO POR EJERCER		
			FEDERAL	ESTATAL	TOTAL	FEDERAL	ESTATAL	TOTAL	FEDERAL	ESTATAL	TOTAL	FEDERAL	ESTATAL	TOTAL	FEDERAL	ESTATAL	TOTAL
5000	BIENES MUEBLES, INMUEBLES E INTANGIBLES		36,540.02	0.00	36,540.02	36,540.02	0.00	36,540.02	36,540.02	0.00	36,540.02	36,540.02	0.00	36,540.02	0.00	0.00	0.00
078	San Cristóbal de las Casas		223,176.00	0.00	223,176.00	223,175.75	0.00	223,175.75	223,175.75	0.00	223,175.75	223,175.75	0.00	223,175.75	0.25	0.00	0.25
5000	BIENES MUEBLES, INMUEBLES E INTANGIBLES		223,176.00	0.00	223,176.00	223,175.75	0.00	223,175.75	223,175.75	0.00	223,175.75	223,175.75	0.00	223,175.75	0.25	0.00	0.25
	RED NACIONAL DE TELECOMUNICACIONES Y SERVICIOS DE LLAMADAS DE EMERGENCIA 066 Y DENUNCIA ANÓNIMA 089 (ECONOMIAS 2011)		378,122.65	753,113.35	1,131,236.00	0.00	0.00	0.00	0.00	0.00	0.00	0.00	0.00	0.00	378,122.65	753,113.35	1,131,236.00
078	San Cristóbal de las Casas		378,122.65	753,113.35	1,131,236.00	0.00	0.00	0.00	0.00	0.00	0.00	0.00	0.00	0.00	378,122.65	753,113.35	1,131,236.00
6000	INVERSION PUBLICA		378,122.65	753,113.35	1,131,236.00	0.00	0.00	0.00	0.00	0.00	0.00	0.00	0.00	0.00	378,122.65	753,113.35	1,131,236.00
	REGISTRO PÚBLICO VEHICULAR		13,978,300.00	7,367,471.81	21,345,771.81	13,489,823.33	6,772,650.35	20,262,473.68	13,489,823.33	6,772,650.35	20,262,473.68	13,444,620.33	6,699,989.29	20,144,609.62	488,476.67	594,821.46	1,083,298.13
1000	SERVICIOS PERSONALES		0.00	4,918,024.88	4,918,024.88	0.00	4,721,174.92	4,721,174.92	0.00	4,721,174.92	4,721,174.92	0.00	4,721,174.92	4,721,174.92	0.00	196,849.96	196,849.96
2000	MATERIALES Y SUMINISTROS		10,000.00	1,079,750.00	1,089,750.00	0.00	936,642.35	936,642.35	0.00	936,642.35	936,642.35	0.00	869,055.89	869,055.89	10,000.00	143,107.65	153,107.65
3000	SERVICIOS GENERALES		3,224,779.44	1,244,360.49	4,469,139.93	2,748,595.69	996,434.26	3,745,029.95	2,748,595.69	996,434.26	3,745,029.95	2,703,392.69	991,353.66	3,694,746.35	476,183.75	247,926.23	724,109.98
4000	TRANSFERENCIAS, ASIGNACIONES, SUBSIDIOS Y OTRAS AYUDAS		0.00	125,336.44	125,336.44	0.00	118,398.82	118,398.82	0.00	118,398.82	118,398.82	0.00	118,398.82	118,398.82	0.00	6,937.62	6,937.62
5000	BIENES MUEBLES, INMUEBLES E INTANGIBLES		10,743,520.56	0.00	10,743,520.56	10,741,227.64	0.00	10,741,227.64	10,741,227.64	0.00	10,741,227.64	10,741,227.64	0.00	10,741,227.64	2,292.92	0.00	2,292.92
	REGISTRO PÚBLICO VEHICULAR (REFERENDO 2014)		2,488,979.36	26,494.64	2,515,474.00	2,488,675.36	26,494.64	2,515,170.00	2,488,675.36	26,494.64	2,515,170.00	2,488,675.36	26,494.64	2,515,170.00	304.00	0.00	304.00
2000	MATERIALES Y SUMINISTROS		0.00	20,623.64	20,623.64	0.00	20,623.64	20,623.64	0.00	20,623.64	20,623.64	0.00	20,623.64	20,623.64	0.00	0.00	0.00
3000	SERVICIOS GENERALES		460,000.00	5,871.00	465,871.00	460,000.00	5,871.00	465,871.00	460,000.00	5,871.00	465,871.00	460,000.00	5,871.00	465,871.00	0.00	0.00	0.00
5000	BIENES MUEBLES, INMUEBLES E INTANGIBLES		1,803,882.36	0.00	1,803,882.36	1,803,578.36	0.00	1,803,578.36	1,803,578.36	0.00	1,803,578.36	1,803,578.36	0.00	1,803,578.36	304.00	0.00	304.00
6000	INVERSION PUBLICA		225,097.00	0.00	225,097.00	225,097.00	0.00	225,097.00	225,097.00	0.00	225,097.00	225,097.00	0.00	225,097.00	0.00	0.00	0.00
	REGISTRO PÚBLICO VEHICULAR (RENDIMIENTOS 2012 Y 2013)		1,431,107.50	0.00	1,431,107.50	1,424,812.34	0.00	1,424,812.34	1,424,812.34	0.00	1,424,812.34	1,424,812.34	0.00	1,424,812.34	6,295.16	0.00	6,295.16
2000	MATERIALES Y SUMINISTROS		300,000.00	0.00	300,000.00	299,251.00	0.00	299,251.00	299,251.00	0.00	299,251.00	299,251.00	0.00	299,251.00	749.00	0.00	749.00
3000	SERVICIOS GENERALES		1,131,107.50	0.00	1,131,107.50	1,125,561.34	0.00	1,125,561.34	1,125,561.34	0.00	1,125,561.34	1,125,561.34	0.00	1,125,561.34	5,546.16	0.00	5,546.16
	REGISTRO PÚBLICO VEHICULAR (RENDIMIENTOS 2014)		80,000.00	0.00	80,000.00	78,996.00	0.00	78,996.00	78,996.00	0.00	78,996.00	78,996.00	0.00	78,996.00	1,004.00	0.00	1,004.00
5000	BIENES MUEBLES, INMUEBLES E INTANGIBLES		80,000.00	0.00	80,000.00	78,996.00	0.00	78,996.00	78,996.00	0.00	78,996.00	78,996.00	0.00	78,996.00	1,004.00	0.00	1,004.00
	REGISTRO PÚBLICO VEHICULAR (ECONOMÍAS 2011, 2012 Y 2013)		3,947,896.49	4,352,103.51	8,300,000.00	3,947,896.40	4,352,103.36	8,299,999.76	3,947,896.40	4,352,103.36	8,299,999.76	3,933,924.27	4,341,158.88	8,275,083.15	0.09	0.15	0.24
2000	MATERIALES Y SUMINISTROS		40,000.00	515,224.00	555,224.00	40,000.00	515,223.95	555,223.95	40,000.00	515,223.95	555,223.95	40,000.00	515,223.95	555,223.95	0.00	0.05	0.05
3000	SERVICIOS GENERALES		810,983.71	634,780.30	1,445,164.01	810,383.70	634,780.30	1,445,164.00	810,383.70	634,780.30	1,445,164.00	796,411.57	629,895.82	1,420,247.39	0.01	0.00	0.01
5000	BIENES MUEBLES, INMUEBLES E INTANGIBLES		3,097,512.78	3,202,099.21	6,299,611.99	3,097,512.70	3,202,099.11	6,299,611.81	3,097,512.70	3,202,099.11	6,299,611.81	3,097,512.70	3,202,099.11	6,299,611.81	0.08	0.10	0.18
	EVALUACIÓN DE LOS DISTINTOS PROGRAMAS O ACCIONES		1,350,000.00	7,445,670.91	8,795,670.91	652,500.00	7,215,746.84	7,868,246.84	652,500.00	7,215,746.84	7,868,246.84	652,500.00	7,215,746.84	7,868,246.84	697,500.00	229,924.07	927,424.07
1000	SERVICIOS PERSONALES		0.00	5,131,316.52	5,131,316.52	0.00	5,082,899.71	5,082,899.71	0.00	5,082,899.71	5,082,899.71	0.00	5,082,899.71	5,082,899.71	0.00	48,422.81	48,422.81
2000	MATERIALES Y SUMINISTROS		0.00	1,016,000.00	1,016,000.00	0.00	971,315.55	971,315.55	0.00	971,315.55	971,315.55	0.00	971,315.55	971,315.55	0.00	44,684.45	44,684.45
3000	SERVICIOS GENERALES		1,350,000.00	1,131,226.31	2,481,226.31	652,500.00	998,156.98	1,650,656.98	652,500.00	998,156.98	1,650,656.98	652,500.00	998,156.98	1,650,656.98	697,500.00	133,099.33	830,599.33
4000	TRANSFERENCIAS, ASIGNACIONES, SUBSIDIOS Y OTRAS AYUDAS		0.00	167,128.08	167,128.08	0.00	163,380.60	163,380.60	0.00	163,380.60	163,380.60	0.00	163,380.60	163,380.60	0.00	3,717.48	3,717.48
	EVALUACIÓN DE LOS DISTINTOS PROGRAMAS O ACCIONES (PROGRAMAS DE SEGUIMIENTO Y EVALUACION) "INDICADORES DE MEDICION REFERENDO 2014"		603,200.00	0.00	603,200.00	603,200.00	0.00	603,200.00	603,200.00	0.00	603,200.00	603,200.00	0.00	603,200.00	0.00	0.00	0.00
3000	SERVICIOS GENERALES		603,200.00	0.00	603,200.00	603,200.00	0.00	603,200.00	603,200.00	0.00	603,200.00	603,200.00	0.00	603,200.00	0.00	0.00	0.00

FORMATO GENERAL
SISTEMA NACIONAL DE SEGURIDAD PÚBLICA
AVANCE EN LA APLICACIÓN DE LOS RECURSOS ASIGNADOS A LOS PROGRAMAS DE SEGURIDAD PÚBLICA 2015
(Cifras al 31 de Diciembre del 2015)
(PESOS)

ENTIDAD FEDERATIVA: CHIAPAS

PROGRAMA	CAPÍTULO	ANEEXO TECNICO/ PROGRAMA CON PRIORIDAD NACIONAL	FINANCIAMIENTO CONJUNTO														
			IMPORTE CONVENIDO			COMPROMETIDO			DEVENGADO			PAGADO			SALDO POR EJERCER		
			FEDERAL	ESTATAL	TOTAL	FEDERAL	ESTATAL	TOTAL	FEDERAL	ESTATAL	TOTAL	FEDERAL	ESTATAL	TOTAL	FEDERAL	ESTATAL	TOTAL
17		FORTALECIMIENTO DE PROGRAMAS PRIORITARIOS DE LAS INSTITUCIONES ESTATALES DE SEGURIDAD PÚBLICA E IMPARTICIÓN DE JUSTICIA	21,680,733.97	3,309,565.39	24,990,299.36	21,519,953.44	3,271,717.36	24,791,670.80	21,519,953.44	3,271,717.36	24,791,670.80	21,519,953.44	3,271,717.36	24,791,670.80	160,780.53	37,848.09	198,628.56
	2000	MATERIALES Y SUMINISTROS	14,532,233.97	2,958,065.39	17,490,299.36	14,372,025.32	2,920,245.48	17,292,270.80	14,372,025.32	2,920,245.48	17,292,270.80	14,372,025.32	2,920,245.48	17,292,270.80	160,208.65	37,819.91	198,028.56
	5000	BIENES MUEBLES, INMUEBLES E INTANGIBLES	7,148,500.00	351,500.00	7,500,000.00	7,147,928.12	351,471.88	7,499,400.00	7,147,928.12	351,471.88	7,499,400.00	7,147,928.12	351,471.88	7,499,400.00	571.88	28.12	600.00
		FORTALECIMIENTO DE PROGRAMAS PRIORITARIOS DE LAS INSTITUCIONES ESTATALES DE SEGURIDAD PÚBLICA E IMPARTICIÓN DE JUSTICIA [REFERENDO 2013 Y 2014]	5,506,795.13	991,835.23	6,498,630.36	4,858,469.17	972,417.65	5,830,886.82	4,858,469.17	972,417.65	5,830,886.82	4,837,326.17	965,687.10	5,803,013.27	648,325.96	19,417.58	667,743.54
	6000	INVERSION PUBLICA	5,506,795.13	991,835.23	6,498,630.36	4,858,469.17	972,417.65	5,830,886.82	4,858,469.17	972,417.65	5,830,886.82	4,837,326.17	965,687.10	5,803,013.27	648,325.96	19,417.58	667,743.54
		FORTALECIMIENTO DE PROGRAMAS PRIORITARIOS DE LAS INSTITUCIONES ESTATALES DE SEGURIDAD PÚBLICA E IMPARTICIÓN DE JUSTICIA [RENDIMIENTO 2013]	3,049,820.98	0.00	3,049,820.98	3,049,820.97	0.00	3,049,820.97	3,049,820.97	0.00	3,049,820.97	3,049,820.97	0.00	3,049,820.97	0.01	0.00	0.01
	2000	MATERIALES Y SUMINISTROS	584,825.60	0.00	584,825.60	584,825.60	0.00	584,825.60	584,825.60	0.00	584,825.60	584,825.60	0.00	584,825.60	0.00	0.00	0.00
	101	Tuxtla Gutierrez	2,464,995.38	0.00	2,464,995.38	2,464,995.37	0.00	2,464,995.37	2,464,995.37	0.00	2,464,995.37	2,464,995.37	0.00	2,464,995.37	0.01	0.00	0.01
	5000	BIENES MUEBLES, INMUEBLES E INTANGIBLES	2,464,995.38	0.00	2,464,995.38	2,464,995.37	0.00	2,464,995.37	2,464,995.37	0.00	2,464,995.37	2,464,995.37	0.00	2,464,995.37	0.01	0.00	0.01

SERVIDOR PÚBLICO QUE ACTUALIZO: LAE ALICIA SÁNCHEZ ROJAS, ANALISTA DEL PROGRAMA EVALUACION DE LOS PROGRAMAS CON PRIORIDAD NACIONAL DEPENDENCIA: SECRETARIADO EJECUTIVO DEL SISTEMA ESTATAL DE SEGURIDAD PUBLICA DEL ESTADO DE CHIAPAS. PWER: <http://www.sesemp.chiapas.gob.mx/> DIRECCION:BOULEVARD, FIDEL VELAZQUEZ 57N CP 29047, TUXTLA GUTIERREZ, CHIAPAS, MEXICO. CONMUTADOR:(961) 6179700, EXTS. 15017 Y/O 15083

Vo. Bo.

Lic. María Alejandra Gutiérrez Moreno
JEFA DE LA UNIDAD DE APOYO ADMINISTRATIVO

Table with columns for AÑO, MES, PROGRAMA, SUBPROGRAMA, CONCEPTO, CUENTA, FONDO, MODALIDAD, and various financial columns (ORIGEN DE USUARIOS, RECURSOS EJERCIDOS, RECURSOS DEVENGADOS, RECURSOS COMPROMETIDOS, RECURSOS DISPONIBLES, META CUBRIDA, META ALCANZADA, META POR ALCANZAR).

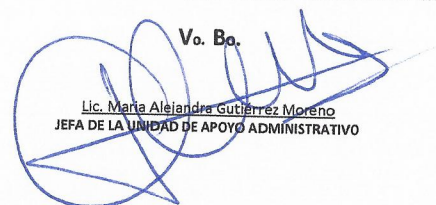

GOBIERNO DEL ESTADO DE CHIAPAS

FORMATO ESPECIFICO FINANCIAMIENTO CONJUNTO PARA LA SEGURIDAD PUBLICA ESTRUCTURA PROGRAMATICA PARA EL FINANCIAMIENTO DE LOS RECURSOS 2015 ENTIDAD FINANCIERA: CHIAPAS



SECRETARIA EJECUTIVA DEL SISTEMA ESTADAL DE SEGURIDAD PUBLICA

Main data table with columns for 'ORIGEN DE LOS RECURSOS', 'RECURSOS EJERCIDOS', 'RECURSOS OBLIGADOS', and 'RECURSOS DISPONIBLES'. It includes sub-sections for 'APORTACIONES FEDERALES (PAF)', 'APORTACIONES ESTATALES', and 'FINANCIAMIENTO'. Rows list various programs and activities with their corresponding budget amounts.

Summary table with columns: META CONVINO Y MODIFICADA, META ANUAL, META PROGRAMADA, META EJECUTADA, META RESERVA, META POR EJECUTAR. It provides a high-level overview of budget execution and commitments.

Table with columns for ADO, PROGRAMA, SUBPROGRAMA, ACTIVIDADES, RECURSOS FEDERALES (FAP), RECURSOS ESTATALES, FINANCIAMIENTO, RECURSOS FEDERALES (FAP), RECURSOS ESTATALES, FINANCIAMIENTO, RECURSOS FEDERALES (FAP), RECURSOS ESTATALES, FINANCIAMIENTO, RECURSOS FEDERALES (FAP), RECURSOS ESTATALES, FINANCIAMIENTO, RECURSOS FEDERALES (FAP), RECURSOS ESTATALES, FINANCIAMIENTO, META CORTA PLAZO, META ANUAL, META PLAZO MEDIANO, META PLAZO LARGO.

Table with columns for ANO, ENTIDAD, PROGRAMA, SUBPROGRAMA, ACTIVIDAD, COMPONENTE, FONTE DE FINANCIAMIENTO, and multiple columns for RECURSOS EJECUTADOS, RECURSOS DEVENGADOS, RECURSOS COMPROMETIDOS, and RECURSOS DISPONIBLES. Includes a 'META CUMPLIDA' section at the bottom right.

FORMATO ESPECÍFICO FINANCIAMIENTO CONTINUO PARA LA SEGURIDAD PÚBLICA SISTEMA ESTADAL DE SEGURIDAD PÚBLICA ESTRUCTURA PROGRAMÁTICA PARA EL SEGUIMIENTO DE LOS RECURSOS 2015 ENTIDAD FEDERATIVA: CHIAPAS

Table with columns for AÑO, ENTIDAD, PROGRAMA, SUBPROGRAMA, COMPONENTE, FONTEAL EJERCIDA, and detailed financial breakdowns for RECURSOS CIRCULOS, RECURSOS DEVENIDOS, RECURSOS COMPROMETIDOS, and RECURSOS EJERCIDOS. Includes sub-headers for APORTACIONES FEDERALES (PAS) and APORTACIONES ESTATALES.

ENTIDAD FEDERATIVA: CHIAPAS

PROGRAMA	CAPÍTULO	ANEXO TECNICO/ PROGRAMA CON PRIORIDAD NACIONAL	FINANCIAMIENTO CONJUNTO														
			IMPORTE CONVENIDO			COMPROMETIDO			DEVENGADO			PAGADO			SALDO POR EJERCER		
			FEDERAL	ESTATAL	TOTAL	FEDERAL	ESTATAL	TOTAL	FEDERAL	ESTATAL	TOTAL	FEDERAL	ESTATAL	TOTAL	FEDERAL	ESTATAL	TOTAL
		PREVENCIÓN SOCIAL DE LA VIOLENCIA Y LA DELINCUENCIA CON PARTICIPACIÓN CIUDADANA (CEPSyPC)	0.00	11,527,275.72	11,527,275.72	0.00	9,254,553.21	9,254,553.21	0.00	9,074,501.42	9,074,501.42	0.00	8,114,758.02	8,114,758.02	0.00	3,412,517.70	2,272,722.51
1	1000	Servicios Personales	0.00	4,183,217.87	4,183,217.87	0.00	4,163,612.34	4,163,612.34	0.00	3,990,770.37	3,990,770.37	0.00	3,990,770.37	3,990,770.37	0.00	192,447.50	19,605.53
	2000	Materiales y Suministros	0.00	212,313.29	212,313.29	0.00	199,588.09	199,588.09	0.00	199,588.09	199,588.09	0.00	199,588.09	199,588.09	0.00	12,725.20	12,725.20
	3000	Servicios Generales	0.00	4,046,834.50	4,046,834.50	0.00	2,323,871.87	2,323,871.87	0.00	2,316,662.05	2,316,662.05	0.00	2,316,662.05	2,316,662.05	0.00	1,730,172.45	1,722,962.63
	4000	Otros Subsidios	0.00	116,900.02	116,900.02	0.00	111,074.81	111,074.81	0.00	111,074.81	111,074.81	0.00	111,074.81	111,074.81	0.00	5,825.21	5,825.21
	5000	Bienes Muebles, Inmuebles o Intangibles	0.00	2,968,010.04	2,968,010.04	0.00	2,456,406.10	2,456,406.10	0.00	2,456,406.10	2,456,406.10	0.00	1,496,662.70	1,496,662.70	0.00	1,471,347.34	511,603.94

Vo.Bo.

LIC. ANA KAREN MONZÓN PÉREZ
 JEFA DEL ÁREA DE APOYO ADMINISTRATIVO

SERVIDOR PÚBLICO QUE ACTUALIZÓ: LIC. JUAN CARLOS CARCINO SANCHEZ, ANALISTA "G" DEL CENTRO ESTATAL DE PREVENCIÓN SOCIAL DE LA VIOLENCIA Y LA DELINCUENCIA CON PARTICIPACIÓN CIUDADANA.
 Dirección: Boulevard, Fidel Velázquez S/N CP 29047, Tuxtla Gutiérrez, Chiapas, México
 Comutador: (961) 6179700, exts. 15015 • <http://www.cesp.chiapas.gob.mx>

CENTRO ESTATAL DE CONTROL DE CONFIANZA CERTIFICADO DEL ESTADO DE CHIAPAS

FORMATO GENERAL
SISTEMA NACIONAL DE SEGURIDAD PÚBLICA
AVANCE EN LA APLICACIÓN DE LOS RECURSOS ASIGNADOS A LOS PROGRAMAS DE SEGURIDAD PÚBLICA 2015
(Cifras al 31 de Diciembre de 2015)
(PESOS)
ENTIDAD FEDERATIVA: CHIAPAS

PROGRAMA	CAPÍTULO	ANEXO TÉCNICO/PROGRAMA CON PRIORIDAD NACIONAL	FINANCIAMIENTO CONJUNTO														
			IMPORTE CONVENIDO			COMPROMETIDO			DEVENGADO			PAGADO			SALDO POR EJERCER		
			FEDERAL	ESTATAL	TOTAL	FEDERAL	ESTATAL	TOTAL	FEDERAL	ESTATAL	TOTAL	FEDERAL	ESTATAL	TOTAL	FEDERAL	ESTATAL	TOTAL
		Fortalecimiento de las Capacidades de Evaluación en Control de Confianza	14,327,433.69	23,584,907.48	\$37,912,341.17	10,316,125.25	21,335,092.08	\$31,651,217.33	10,316,125.25	21,335,092.08	\$31,651,217.33	10,316,125.25	21,335,092.08	\$31,651,217.33	4,011,308.44	2,249,815.40	\$6,261,123.84
	1000	Servicios Personales	0.00	20,971,073.60	20,971,073.60	0.00	19,532,813.48	19,532,813.48	0.00	19,532,813.48	19,532,813.48	0.00	19,532,813.48	19,532,813.48	0.00	1,438,260.12	1,438,260.12
	2000	Materiales y Suministros	4,336,219.94	376,328.00	4,712,547.94	4,285,416.88	330,642.99	4,616,059.87	4,285,416.88	330,642.99	4,616,059.87	4,285,416.88	330,642.99	4,616,059.87	50,803.06	45,685.01	96,488.07
2	3000	Servicios Generales	1,554,833.78	1,651,293.25	3,206,127.03	313,073.78	931,508.34	1,244,582.12	313,073.78	931,508.34	1,244,582.12	313,073.78	931,508.34	1,244,582.12	1,241,760.00	719,784.91	1,961,544.91
	4000	Transferencias, Asignaciones, Subsidios y Otras Ayudas	0.00	586,212.63	586,212.63	0.00	540,127.27	540,127.27	0.00	540,127.27	540,127.27	0.00	540,127.27	540,127.27	0.00	46,085.36	46,085.36
	5000	Bienes Muebles, Inmuebles e Intangibles	3,984,328.02	0.00	3,984,328.02	1,298,831.36	0.00	1,298,831.36	1,298,831.36	0.00	1,298,831.36	1,298,831.36	0.00	1,298,831.36	2,685,496.66	0.00	2,685,496.66
	6000	Inversión Pública	4,452,051.95	0.00	4,452,051.95	4,418,803.23	0.00	4,418,803.23	4,418,803.23	0.00	4,418,803.23	4,418,803.23	0.00	4,418,803.23	33,248.72	0.00	33,248.72

* Fuente de Información: Estado Presupuestal que emite el Síste con corte al 31 de Diciembre del 2015.

Lic. Ildemaro Archila Ferrera
Jefe de la Unidad de Planeación

